

## MATERIALS OF CONSTRUCTION

PART	MATERIAL
1. Body	Stainless Steel, CF8M (SS316)
2. Bonnet Shell	Aluminium Alloy
3. Hand Wheel	Powder Coated Aluminium Alloy
4. Spindle	SS304, SS316
5. Diaphragm	See Table 1
6. Compressor	Aluminium Alloy
7. Fasteners	304, Stainless Steel
8. Hand Wheel Pin	Spring Steel

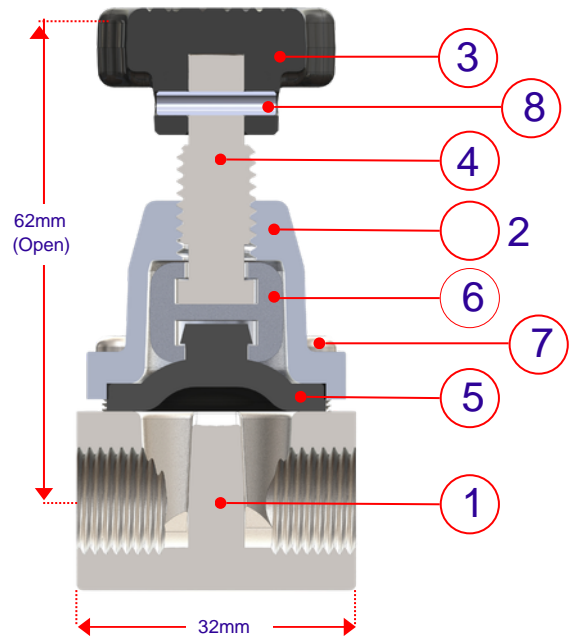

TABLE 1 - DIAPHRAGM GRADE AND MATERIALS

GRADE	MATERIALS
10	Natural Rubber NR
20	EPDM/Black Ethylene Propylene Rubber
22	EPDM/Food Grade (FDA)
30	Butyl Rubber IIR Chlorobutyl - Isobutylene Isoprene Halogenated
40	Nitrile Rubber NBR Acrylonitrile Butadiene Rubber
50	Neoprene CR Chloroprene Rubber
60	Hypalon CSM Chlorosulfonated Polyethylene
70	FKM/Viton FPM Fluorinated Elastomer



## PRESSURE RATING

### ELASTOMER DIAPHRAGMS

1/4" (DN8) - 3/8" (DN10)      16 Bar (1600 kPa | 232 PSI)

## MATERIAL SPECIFICATIONS

- Stainless Steel (ASTM A351 Gr CF8M)
- Aluminium Standard (JIS-H5302)

## TESTING STANDARDS

EN12266-2 2002 (BS6755 Part 1)

## THREAD STANDARDS

- ANSI B2.1 NPT
- AS1722.1 Part 1
- BSPP

## DESIGN STANDARDS

EN13397-2001 (BS5156:1985)

## ALSO AVAILABLE IN 3/8" (DN10)

KDV offers both 1/4" (DN8) and 3/8" (DN10) valves, the latter being a universal fit for many pipelines.

The 3/8" size provides better flow capacity and minimal pressure drop, ideal for operations requiring higher throughput without sacrificing cleanliness or reliability.





3/8" (10mm)





1/4" (8mm)

[www.kdvflow.com](http://www.kdvflow.com)

 **Head Office | Australia**  
**Email:**  
[info@kdvflow.com](mailto:info@kdvflow.com)  
 **Dubai**  
**Email:**  
[info@kdvflow.com](mailto:info@kdvflow.com)

 **United Kingdom**  
**Email:**  
[info@kdvflow.co.uk](mailto:info@kdvflow.co.uk)

 **China**  
**Email:**  
[info@kdvflow.com](mailto:info@kdvflow.com)

 **Thailand**  
**Email:**  
[info@kdvflow.co.th](mailto:info@kdvflow.co.th)

 **India**  
**Email:**  
[info@kdvflow.com](mailto:info@kdvflow.com)

 **Singapore**  
**Email:**  
[info@kdvflow.com](mailto:info@kdvflow.com)

 **Philippines**  
**Email:**  
[info@kdvflow.com](mailto:info@kdvflow.com)